

THIS DRAWING IS UNPUBLISHED. RELEASED FOR PUBLICATION
 © COPYRIGHT BY TYCO ELECTRONICS CORPORATION. ALL RIGHTS RESERVED.

LOC	DIST	REVISIONS					
		P	LTR	DESCRIPTION	DATE	DWN	APVD
G	14		M	REV PER 0G3A-0092-05	08FEB05	JR	TM

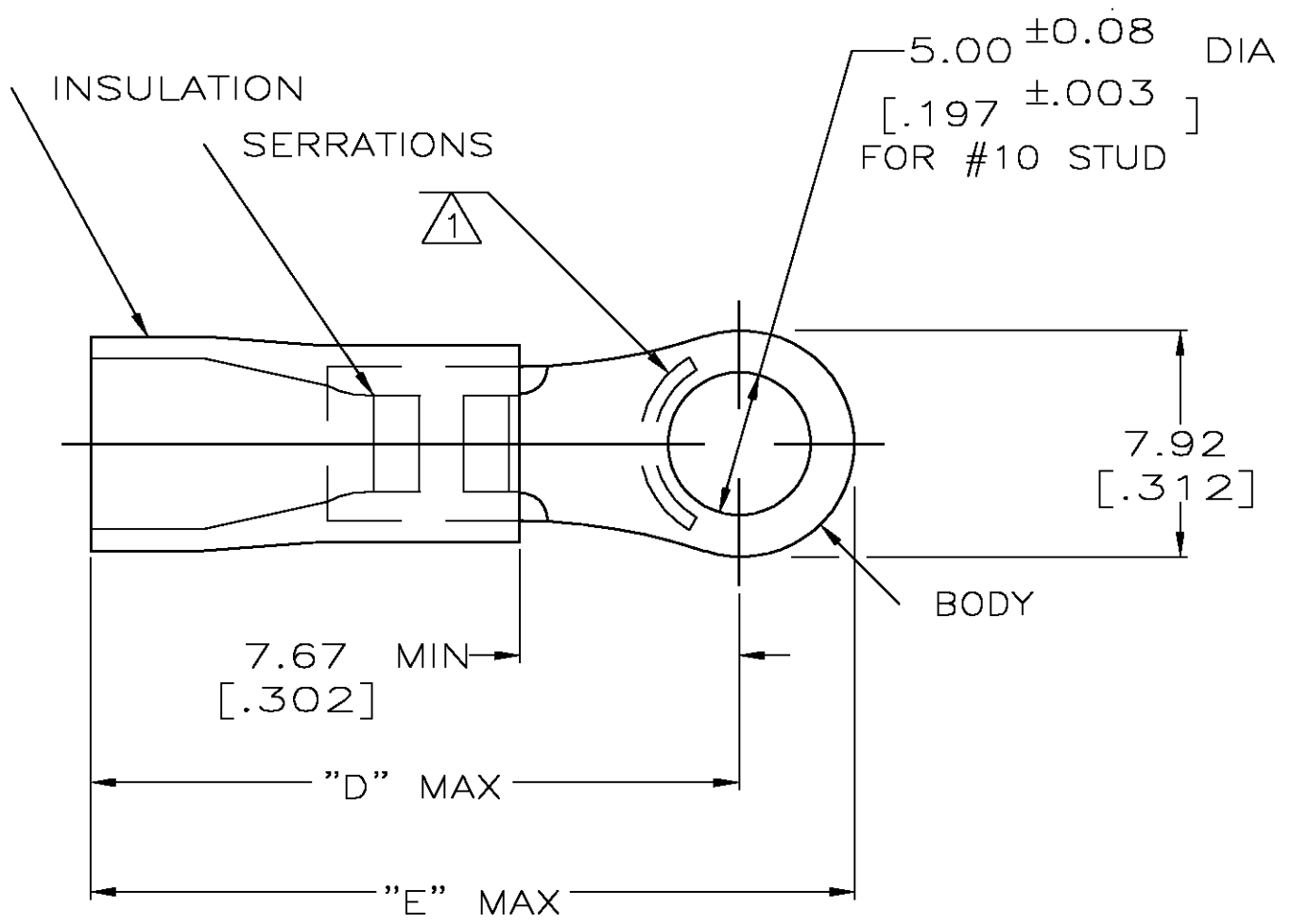

- 1 STAMP AMP 12-10*, APPROX AS SHOWN
- 2 TONGUE MATERIAL THK IS 0.99±0.05 [.039±.002]
- 3 MATERIAL: BODY; COPPER PER ASTM B152
INSULATION; PVC
COLOR; YELLOW
- 4 FINISH: BODY; TIN PL. PER ASTM B545

AMP WIRE RANGE	Listed	LR7189 Certified
12-10 AWG SOLID OR STRANDED	12-10 AWG SOLID OR STRANDED	12-10 AWG SOLID OR STRANDED

"E"	"D"	WIRE INSULATION DIA	QTY	PACKAGE TYPE	PART NUMBER
28.00 [1.111]	24.21 [.953]	5.08-7.62 [.200-.300]	500	LOOSE PIECE	1-330518-1
26.72 [1.052]	22.68 [.893]	3.81-6.35 [.150-.250]	1500	ON TAPE, REEL	1-330518-2
26.72 [1.052]	22.68 [.893]	3.81-6.35 [.150-.250]	500	LOOSE PIECE	330518

AMP INCORPORATED CUSTOMER SERVICE SYSTEMS		MAX RECOMMENDED OPERATING TEMPERATURE: 105°C [221°F]	THIS DRAWING IS A CONTROLLED DOCUMENT.		DWN DK SCHRUM 08/06/92	Tyco Electronics Corporation Harrisburg, Pa 17105-3608			
FOR ADDITIONAL PRODUCT INFORMATION OR COPIES OF DRAWINGS AND TECHNICAL DOCUMENTS	PRODUCT INFORMATION CENTER 1-800-522-6752	VOLTAGE RATING: N/A	DIMENSIONS: mm [INCHES]	TOLERANCES UNLESS OTHERWISE SPECIFIED:	CHK RE HERSEY 11/10/92	NAME M ELLIS 11/10/92			
FOR APPLICATION TOOLING INFORMATION	TOOLING ASSISTANCE CENTER 1-800-722-1111	CIRCULAR MIL AREA: 2.62-6.64mm² [5180-13100] SOLID OR STRANDED		0 PLC ± - 1 PLC ± - 2 PLC ± 0.20[.008] 3 PLC ± - 4 PLC ± - ANGLES ± -	APVD M ELLIS 11/10/92	PRODUCT SPEC UL 486A			
FOR ORDER ENTRY	1-800-526-5142	THIS DRAWING IS A CONTROLLED DOCUMENT FOR AMP INCORPORATED. IT IS SUBJECT TO CHANGE AND THE CONTROLLING ENGINEERING ORGANIZATION SHOULD BE CONTACTED FOR THE LATEST REVISION.	MATERIAL - 3	FINISH - 4	APPLICATION SPEC NOT AVAILABLE	SIZE A3	CAGE CODE 00779	DRAWING NO C-330518	RESTRICTED TO -
CUSTOMER DRAWING					WEIGHT -	SCALE 4:1	SHEET 1 OF 1	REV M	